

eLockIn 204

4-phase DSP lock-in amplifier

– Manual –

- LOCK-IN AMPLIFIER 10 mHz TO 1 MHz
- SPECTRUM ANALYZER
- DATA ACQUISITION
- DIGITAL OSCILLOSCOPE



November 2010

Anfatec Instruments AG
Melanchthonstr. 28
08606 Oelsnitz /V.
Tel.: +49 (0) 37421 24212
Tel.: +49 (0) 37421 24221
<http://www.anfatec.de>
email: mailbox@anfatec.de

TABLE OF CONTENTS

1 Introduction.....	5
1.1 General Functions.....	5
1.1 Specifications.....	6
1.1.1 Lock-In Amplifier.....	6
1.1.2 Oscilloscope:	7
1.1.3 AUX In.....	7
1.1.4 AUX Out.....	7
2 Lock-In Basics.....	8
2.1 Lock-In Amplification.....	8
2.2 Mathematical Description.....	8
2.3 Characteristical Curves of a Lock-In Amplifier.....	10
2.4 Noise Measurements.....	11
2.5 Example: Electrical Force Microscope.....	12
3 Users manual.....	14
3.1 Technical introduction.....	14
3.1.1 Front Panel.....	14
3.1.2 Screen Organization.....	15
3.1.3 The Menu Tree.....	16
3.1.4 Rear Panel.....	17
3.2 The LockIn Menu [LockIn]	18
3.2.1 Input Settings [LockIn / Input].....	18
3.2.2 Reference Output [LockIn / Ref].....	21
3.2.3 Display Settings [LockIn / Display].....	21
3.2.4 AUX Out [LockIn / Out].....	22
3.3 The Spectra Menu [Spectra].....	23
3.3.1 Run/Stop [Spectra / Run] or [Spectra / Stop].....	23
3.3.2 Display [Spectra / Display].....	23
3.3.3 Acquire [Spectra / Acquire].....	24
3.3.4 Save [Spectra / Save].....	25
3.4 Oscilloscope [Scope].....	25
3.4.1 Run/Stop [Scope / Run] or [Scope / Stop].....	26
3.4.2 Display [Scope / Display].....	26
3.4.3 Acquire [Scope / Acquire].....	26
3.4.4 Save [Scope / Save]	26
3.5 Measure [Measure].....	27
3.6 Setup [Setup].....	27
3.7 Handling of parameter settings.....	28
3.8 FTP Data Access.....	28
3.9 HTTP Web Access.....	28
3.10 Known Problems.....	29
4 Remote Control.....	30
4.1 Accessing the eLockIn Using the CGI Interface.....	30
4.1.1 Requirements.....	30
4.1.2 Authentication.....	30
4.1.3 Sending Key Codes to the eLockIn.....	31
4.1.4 Setting Values.....	32

4.1.5 Retrieving Screenshots.....	36
4.1.6 Retrieving Channel Values.....	36
4.1.7 Get Internal Settings and Status Information.....	37
4.1.8 Example Program: LockInRemote.....	37
4.2 Use CGI-Functions via Web Browser.....	39
4.3 Exported functions of the eLockin.dll.....	39
4.4 Remote control for the eLockIn in LabView	40
4.4.1 TCP/IP access by LabView.....	40
4.4.2 DLL based access by LabView.....	42
5 Software-Update.....	44
6 Revision History.....	45
6.1 Manual Revisions.....	45
6.2 Hardware Revisions.....	45
6.3 Software revision.....	45
7 Appendices.....	46
7.1 Schematic diagram of the signal paths.....	46
7.2 Calibration Certificate.....	47
7.3 Traceability Chart.....	47

The manual uses the following style declarations to visualize certain meanings:

This style describes shortly, how to reach a parameter in the menus. The list of buttons to be pressed is written usually in these brackets: [...].

Parameter names changeable in the menus are written in this style.

The parameter values have this style.

In contrast to parameters which are hidden behind some menu entries, the main menus as LockIn, Measure, ... are directly accessible by buttons, which are written in this style. Also, file names used for the remote programming are written in this style.

Examples are written like this.

Notes to the user that might be helpful are shown in this style.

Copyright 2002-2012 Anfattec Instruments AG. All rights reserved. Anfattec, AMU and eLockIn are trademarks of Anfattec. Other product and brand names may be trademarks or registered trademarks of their respective owners.

Anfattec Instruments AG assumes no responsibility for any damage or loss resulting from use of this handbook.

Anfattec Instruments AG assumes no responsibility for any damage or loss resulting from use of the software. Anfattec Instruments AG assumes no responsibility for any damage or loss by deletion of data as a result of malfunction, dead battery, or repairs. Be sure to make backup copies of all important data on other media to protect against data loss. Using any part of the software indicates that you accept the terms of Anfattec Software License Agreement.

Manual date: 04/17/12

1 INTRODUCTION

1.1 GENERAL FUNCTIONS

The eLockIn model 204 is a versatile scientific instrument that supports the following functions:

LockIn Amplifier
Digital Oscilloscope
Spectrum Analyzer
Data Acquisition

The instrument works as a stand-alone device with a 5.6 inches TFT display. Its internal functionality is best described with the following overall schematics:

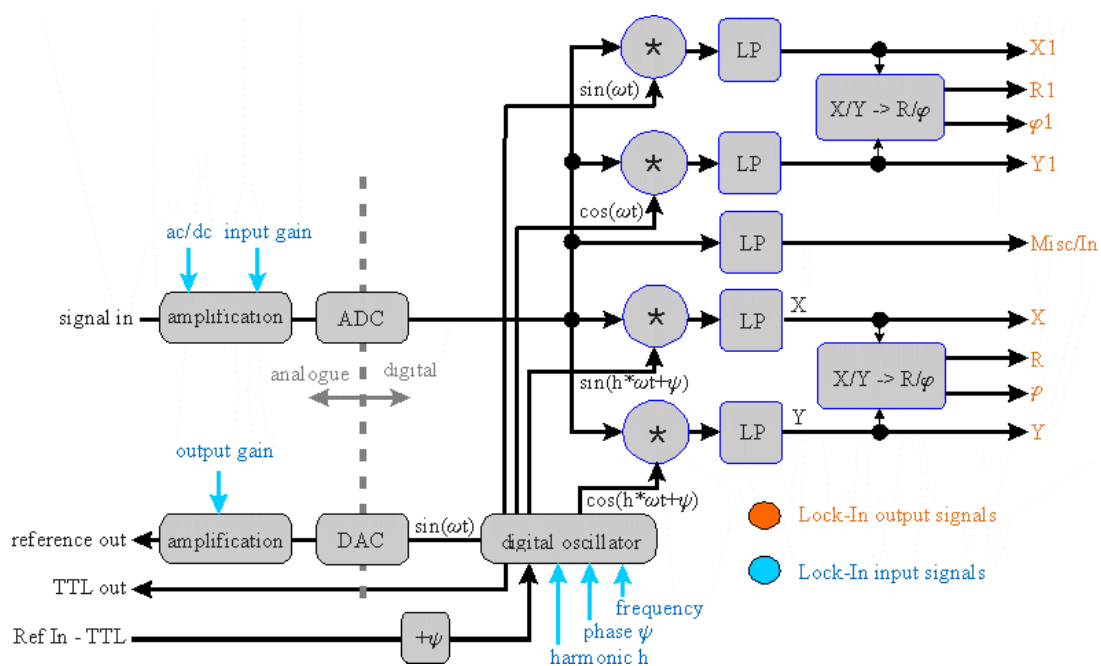

Figure 1: Schematic diagram with the basic components of the lock-in amplifier.

The signal which has to be analyzed runs through some analogue amplification stages whose 3 dB bandwidth is 1 MHz. It is converted with a 40 MHz sampling rate. The whole lock-in analysis is realized in a fully digital design. The digital oscillator output signal is D/A-converted with a rate of 20 MHz and amplified to provide the reference output for the user.

All internal signals marked in green (output) or blue (input) color are handled with a 40 kHz rate, so that the shortest time constant available in the system is 25 μ s. Further 96 bit digital low-pass filters extend the time constant range up to 1 ks. The user has access to all lock-in inputs and lock-in outputs as well as to 8 additional analogue input channels which are converted with 24 bit @ 40 kHz.

Out of this signal variety, the user selects 4 signals in order to display them in acquired frequency spectra or in the oscilloscope screen.

Besides these general functions, the eLockIn204 provides:

- ◆ 32 megabytes of internal data storage
- ◆ USB connection for external flash memory (USB flash drive)
- ◆ ethernet access via ftp and http
- ◆ http-server for remote control

Note: When the **Harm**onic is set to **1**, the signals **Xn, Yn, Rn** and **Phin** are displayed as **X, Y, R,** and **Phi** and equal the results provided as **X1, Y1, R1** and **Phi1**.

1.1 SPECIFICATIONS

1.1.1 LOCK-IN AMPLIFIER

General

Digital Quad ⁽¹⁾ -Phase Lock-In Amplifier	
Dynamic Reserve	> 135 dB ⁽¹⁾
Noise	< 6 nV _{rms} /Hz ^{0.5} @100kHz ⁽¹⁾
Remote Control ⁽¹⁾	Ethernet
Time Constants	0.1 ms ... 1 ks ⁽¹⁾
Sensitivity	10 nV ... 10 V
Phase Resolution	0.001°

Signal Input

Voltage Input	BNC
Input Coupling	DC or AC (f _{3dB} =2Hz)
Input Impedance	1 MΩ 10 pF
Damage Threshold	+/- 12 V
Bandwidth	dc to 1 MHz (f _{3dB} >1 MHz)
Full Scale Input Ranges	± 5 V, ± 500 mV, ± 50 mV ⁽¹⁾
Input Noise:	U _{ac} = 0 V, 50 Ω @ input
@ 100 kHz, high dynamic	< 300 nV _{rms} /Hz ^{0.5} ⁽¹⁾
@ 100 kHz, normal dynamic	< 50 nV _{rms} /Hz ^{0.5} ⁽¹⁾
@ 100 kHz, low dynamic	< 6 nV _{rms} /Hz ^{0.5} ⁽¹⁾
Roll-Off	6 dB/oct, 12 dB/oct, 24 dB/oct
Time Constants	0.1 ms to 1 ks in 1-2-5 steps ⁽¹⁾ or in Sync-Mode: 1/f to 200/f in 1-2-5 steps
Gain Deviations between Dynamic Ranges:	< 5 %

Reference Output (for access to the TTL Ref. output see Appendix)

Internal Oscillator	10 mHz .. > 1 MHz ⁽¹⁾
Frequency Resolution	10 mHz ⁽¹⁾
Frequency Accuracy	+/- 50 ppm from 0 °C to 70 °C
Reference Output Voltage	< 1 mVpp ... 15 Vpp
Output Noise	U _{ac} = 1 mV
@ 100 kHz	< 200 nV _{rms} /Hz ^{0.5}

PLL

Frequency Range	1 Hz .. 1 MHz
Locking Time	< (100 ms+ 10 Cycle)
Phase Error	< 4 deg @ f = 1 kHz
Input Amplitude	CMOS compatible, see Page or sine signal > 100 mV _{rms}
Input Impedance for sine	1 MΩ (small signals) 1 kΩ (large signals)

1.1.2 OSCILLOSCOPE:

Available Channels	Lock-in channels of any harmonic (R, φ, X, Y) 8 external A/D-channels (AD1..8) 3 internal channels (f, U _{ac} , In) 1 st harmonic Lock-in channels (R1, φ1, X1, Y1)
Maximum Number of Simultaneously Displayed Channels	4
Sampling Rate	39.062 kHz

1.1.3 AUX IN

Number of Available Channels	8
Input Range	± 10 V
Sampling Rate	39.062 kHz
Resolution	24 Bit

1.1.4 AUX OUT

Number of Available Channels	8
Output Range	± 10 V
Sampling Rate	39.062 kHz
Resolution	24 Bit

(1)

2 LOCK-IN BASICS

2.1 LOCK-IN AMPLIFICATION

The lock-in amplifier is a measuring instrument for extracting and amplifying low signals from noise by means of a correlation analysis. For this method, it is necessary to know about the time dependence of the signal to be measured. Practically this signal is modulated at a certain reference frequency ω_{ref} and the resulting frequency spectrum is simultaneously analyzed at ω_{ref} . For analyzing the input signal the lock-in amplifier transforms the time-dependent signal at ω_{ref} into the frequency domain and averages it during the time τ . In other words, the lock-in amplifier can be described as a narrow-band amplifier with the center frequency ω_{ref} and a bandwidth that is determined by the time constant τ .

A schematic diagram with the basic components of the lock-in amplifier is shown in Figure on page . First of all the received signal is amplified and digitized. Divided into two separate channels, the signal is multiplied by the mentioned reference signal (with frequency ω_{ref}) and the 90° phase-shifted reference signal respectively. The reference signal is generated with the lock-in's digital oscillator. An additional implemented phase displacement ψ enables to compensate phase differences caused by the measuring equipment. After multiplication, the resulting signals are low-pass filtered and provide now information about the real part X and the imaginary part Y of the analyzed signal relating to the phase position of the reference signal. Out of them the amplitude R as well as the relative phase shift φ are calculated.

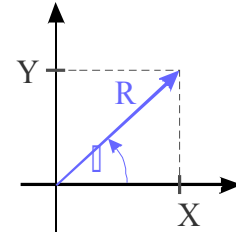

2.2 MATHEMATICAL DESCRIPTION

In this chapter, a short mathematical description of the multiplication and integration steps as the key procedures of a digital lock-in amplifier is given.

For instance, one tries to analyze the noisy signal $s(t)$ that depends on a value $v(t)$. $v(t)$ itself may consist of a constant part v_0 and an additional periodic time-dependent part with the amplitude v_1 and the frequency ω_{ref} : $v(t) = v_0 + v_1 \cos(\omega_{ref} t)$. The latter term modulates the analyzed signal amplitude $s(v(t))$.

Then, $s(v(t))$ can be developed into a Taylor series:

$$s(v_0 + v_1 \cos(\omega_{ref} t)) = \sum_{k=0}^{\infty} s^{(k)}(v_0) \cdot \frac{v_1^k}{k!} \cdot \cos^k(\omega_{ref} t) \quad (1a)$$

$$\text{with the derivatives } s^{(k)}(v_0) = \left. \frac{d^k s}{d v^k} \right|_{v=v_0} \quad k \in \mathbb{N} . \quad (1b)$$

Inside the lock-in amplifier $s(v(t))$ is multiplied by the reference signal with frequency ω_{ref} and integrated over the time τ . That means, in order to determine the value of $s(t)$ at the time t , all measured values in the past time interval τ have to be taken into account. Therefore τ should be a multiple of $2\pi/\omega_{ref}$ or bigger because it should contain at least one period of oscillation to receive correct results.

Beside the modulation at ω_{ref} , modulations of $s(t)$ at the frequencies $m \cdot \omega_{ref}$ with $m = 1, 2, \dots$ (1st, 2nd, ... harmonic) are expected. For that reason the lock-in amplifier calculates the following Fourier components $S(m \cdot \omega_{ref})$ in the frequency domain from the input signal $s(t)$ in

the time domain:

$$S(m \cdot \omega_{ref}) = \frac{1}{\tau} \int_{-\tau/2}^{\tau/2} s(v(t)) \cdot e^{-i m \omega_{ref} t} dt \quad (2)$$

Together with equation (1) one receives the desired dependency of the measured signal on the value of v_0 at the frequencies $m \cdot \omega_{ref}$:

$$S(m \cdot \omega_{ref}) = \sum_{k=0}^{\infty} s^{(k)}(v_0) \frac{v_1^k}{k!} K_m^k \quad (3a)$$

with

$$K_m^k = \frac{1}{\tau} \int_{-\tau/2}^{\tau/2} \cos^k(\omega_{ref} t) \cdot e^{-i m \omega_{ref} t} dt \quad (3b)$$

Although the factors K_m^k converge to zero for k to infinity, some factors remain different from zero. Series elements of the n^{th} order are also negligible if the corresponding n^{th} derivative of $s(v_0)$ is negligible, too.

The factors K_m^k for the first four harmonics are shown in the table below:

	k =									
m	1	2	3	4	5	6	7	8	9	10
1	$\frac{1}{2}$		$\frac{3}{8}$		$\frac{5}{16}$		$\frac{35}{128}$		$\frac{63}{256}$	
2		$\frac{1}{4}$		$\frac{1}{4}$		$\frac{15}{64}$		$\frac{7}{32}$		$\frac{105}{512}$
3			$\frac{1}{8}$		$\frac{5}{32}$		$\frac{21}{128}$		$\frac{21}{128}$	
4				$\frac{1}{16}$		$\frac{3}{32}$		$\frac{7}{64}$		

2.3 CHARACTERISTICAL CURVES OF A LOCK-IN AMPLIFIER

For filtering different information out of a received signal the corresponding frequency ranges ought not to overlap. The following experiment shows how small the difference between the frequencies should be that they can be analyzed independently:

A sinusoidal signal with a frequency of 100 kHz and an amplitude of 20 mV_{rms} is fed in to the input of the lock-in amplifier. By sweeping the lock-in's reference frequency ω_{ref} around 100 kHz the frequency spectrum of the input signal is analyzed. In Figure 2, the output of the lock-in amplifier is plotted in dependence on ω_{ref} for different values of damping (Roll-Off = 6 dB/octave, 12 dB/octave and 24 dB/octave). The time constant τ has been kept constant.

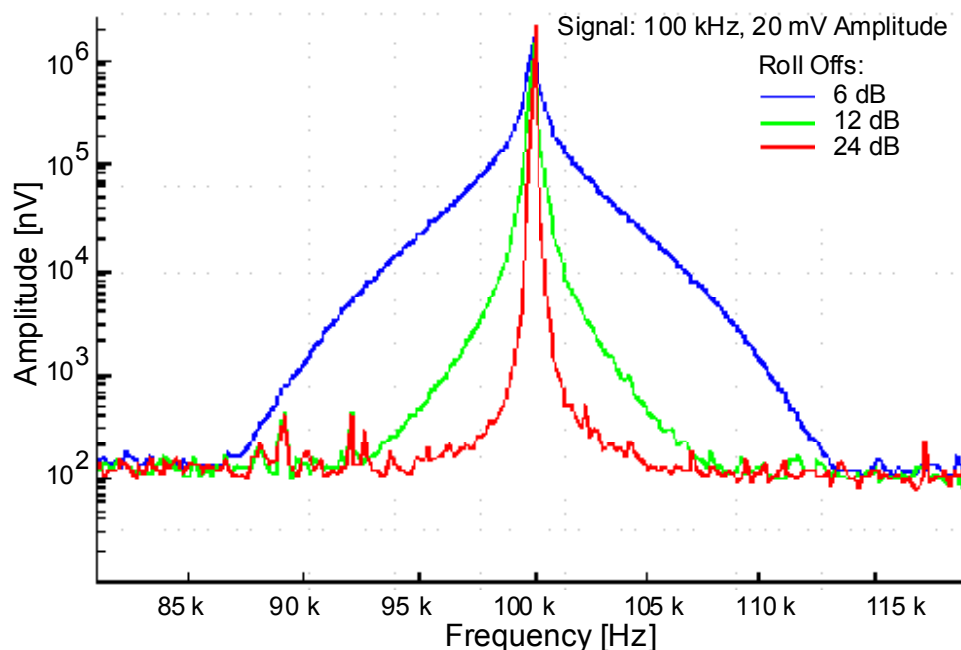

Figure 2 Output signal of a lock-in amplifier for a single frequency input signal of 100 kHz and 20 mV_{rms} amplitude at the input. The time constants have been kept constant.

For a damping of 6 dB/oct, the measured amplitude at 95 kHz drops to approximately 1 % regarding to the maximal value at 100 kHz. For 24 dB/oct, the amplitude at 95 kHz is practically not measurable. So the curves show that the lock-in amplifier uses a very narrow frequency band for signal detection.

2.4 NOISE MEASUREMENTS

Lock-in amplifiers are capable to measure noise. They detect a signal at a certain center frequency ω_{ref} with a equivalent noise bandwidth. For a Gaussian noise, the equivalent noise bandwidth of a real low pass filter is the bandwidth which passes the same amount of noise as a perfect rectangular filter with the equivalent noise band width.

The equivalent noise bandwidth of the **eLockIn** is determined by the time constant and the slope of the used Butterworth filter. It is calculated by

$$B_n = \int_0^{\infty} \frac{1}{1 + \omega^{2n}} d\omega \quad (4)$$

The normalized Butterworth filter noise bandwidths are:

<i>Filter order</i>	<i>Bandwidth / τ</i>
1	1,570796
2	1,110721
4	1,026172

In order to measure noise spectra, the resulting data should be divided by the square-root of the used bandwidth.

The integrated spectrum is taken with a time constant of 10 ms and a slope of 24 dB (4th order) - bandwidth factor ~ 1,03. The related bandwidth is then 1/10 ms = 100 Hz. In order to interpret the result as noise in units of V/Hz^{0.5}, the spectrum should be divided by 10 Hz^{0.5} (= sqrt(100 Hz)).

A possible voltage dependency of C is neglected in this consideration.
 The voltage U contains a direct voltage part U_{DC} and an alternating voltage part U_{AC} :

$$U = U_{DC} + U_{AC} \cdot \cos(\omega_{ref} t) \quad . \quad (6)$$

U_{DC} consists of an additional applied bias voltage and, what is especially interesting from the physical point of view, potential differences caused by different electronic work functions and charges. For separating the impact of these electrical forces from other forces (e.g. van der Waals forces), U has to be modulated at the frequency ω_{ref} . As a result of this, the measurable photo-detector signal is modulated, too.

Inserting equation (6) in (5) and using power-reduction formulas of trigonometric functions one can expect a force between tip and sample at the frequency ω_{ref} as well as at $2 \cdot \omega_{ref}$. Figure 3 confirms this prediction: It shows the frequency spectrum of the cantilever oscillation with clear signals at the mechanical excitation frequency ω_r and at the frequencies of the first and second harmonic of the electrical excitation.

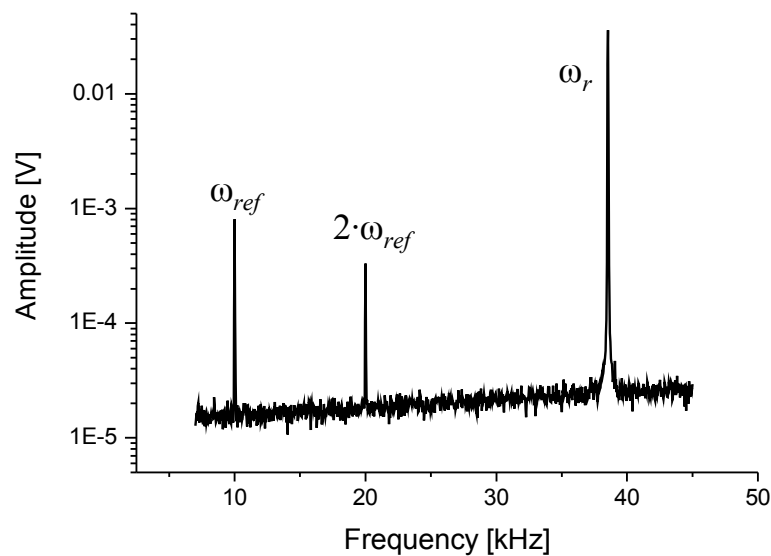

Figure 4: Frequency spectrum of the oscillating cantilever

Now two additional lock-in amplifiers (see Figure) can be used to analyze the photo-detector signal at the frequency ω_{ref} and $2 \cdot \omega_{ref}$ simultaneously. The measured amplitudes of the signals are proportional to the strength of the electrical forces.

3 USERS MANUAL

This manual part describes where to find and how to change a parameter. It also gives an overview of the front panel and rear panel structure. An abbreviation like [LockIn / Ref / f] means that the user has to press the buttons "LockIn" → "Ref" → "f" one after the other.

3.1 TECHNICAL INTRODUCTION

3.1.1 FRONT PANEL

◆ Connectors / Switches:

- **In:** Signal input of the lock-in amplifier,
- **Power:** Main on/off button of the instrument,
- **Ref Out:** The lock-in amplifier reference output.

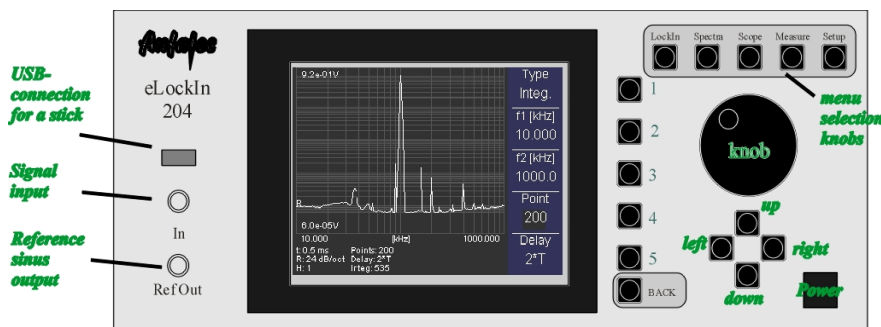

Figure 5: The front panel.

◆ Fixed Navigation Buttons:

- **Knob:** Use this knob to change the selected parameter fast. When the knob is turned in a clockwise direction, the selected parameter will be increased. When it is turned counterclockwise, the selected parameter will be decreased. Use the **pushbutton** in the knob to switch between menu meanings.
- **Up / Down:** These two buttons increase / decrease the value of the selected parameter stepwise.
- **Left / Right:** These buttons move the cursor in the selected parameter input field one digit to the left or to the right. The digit that can be changed with the **Up** and **Down** buttons is always the marked digit.

◆ Variable Navigation Buttons:

- **Button No. 1 to 5:** Selects the function left besides the button.
- **Back:** Goes one step upwards in the menu structure.

◆ Menu Selection Buttons:

- **LockIn:** This is the control key to enter the **LockIn** mode. In the **LockIn** mode, parameters connected with the **LockIn** function can be changed. In addition, the channels to be displayed in the oscilloscope and spectra mode as well as the output signal and the scaling of the DA-channels can be modified here.

- **Spectra:** This is the control key for the **Spectra** acquisition mode. The displayed channels are selected in the **LockIn** mode.
- **Scope:** Press this button to turn the instrument into Oscilloscope mode. The displayed channels are selected in the **LockIn** mode.
- **Measure:** This menu provides certain functions which make the usage of the instrument easier, such as the frequency selection in a recorded spectrum.
- **Setup:** In this menu the user can change some basic setup parameters, such as the IP address of the device or the warning signal.

Note: When the parameters reach their maximum or minimum value, the increase or the decrease actions have no effect.

3.1.2 SCREEN ORGANIZATION

The screen is divided into three parts:

- the main screen
- the menu display and
- the parameter display.

While the menu display helps to navigate through the parameter menus, the main screen contains information, which is specific for the selected mode of the device. The parameter display provides information, which is usually hidden behind several menu entries.

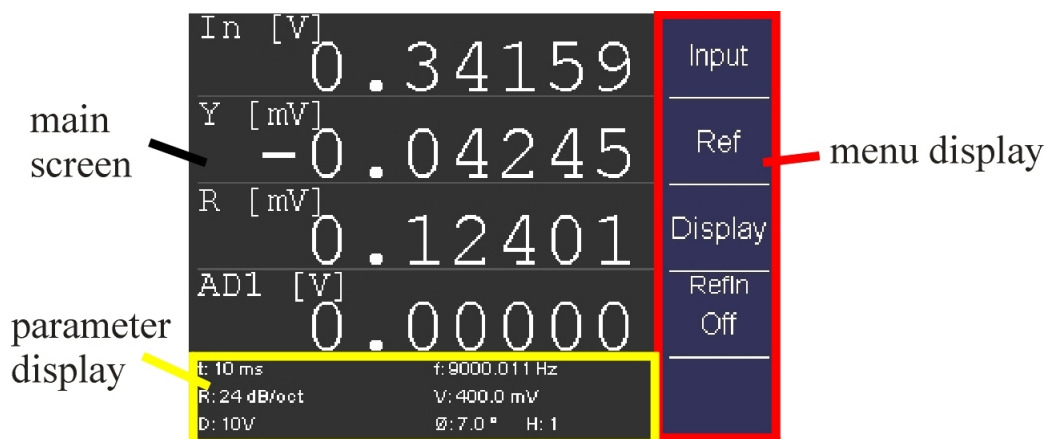

Figure 6: Screen organization at the example of the LockIn menu.

The main screen shows:

- ◆ current values of selected channels in **LockIn** mode,
- ◆ acquired data in **Spectra** mode and Oscilloscope mode and
- ◆ system parameters in the **Setup** mode.

The menu gives access to parameters. The menu trees are shown in the Figures 6 to 7. Note that each menu entry consists of a name and some have a value.



This menu entry consists of a **name** "f1 [kHz]" and a **value** "10.000". The value can be changed with the **Up** and **Down** functions.

This entry consists of a **name** only. It usually leads to a sub-menu.



3.1.3 THE MENU TREE

The five top base menus are selected with the Menu Selection buttons listed in on page . The submenus are shown in the following pictures:

When [LockIn] is pressed, the first line of the menu structure mentioned in Figure 6 is shown in the menu screen, which means **Input** in the first line, **Ref** in the second line and **Display** in the third line.

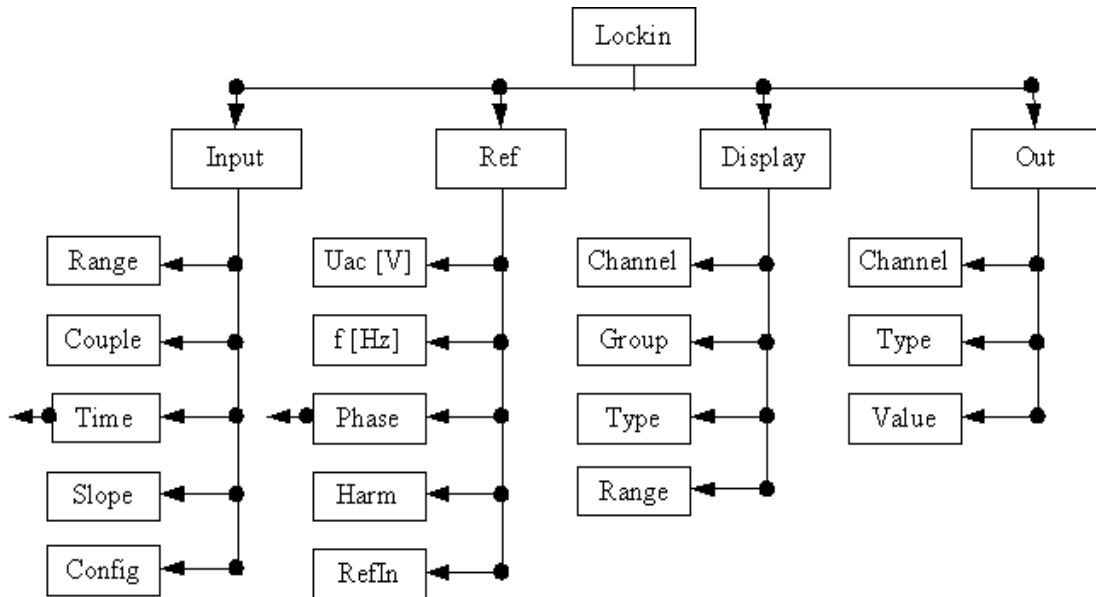

Figure 7 Menu structure of the LockIn mode.

When now **Input** is selected, the menu items will change to **Range** in the first, **Couple** in the second, **Time** in the third and **Slope** in the fourth line. Out of these four items, the selected item is perceptible from

the darker background color. In order to select another item, press the button right of it once. In order to change a number displayed below the name, use the **Left / Right** functions to select the digit and the **Up / Down** function to change it.

The corresponding structures of the **Spectra** and the **Scope** menus are shown below:

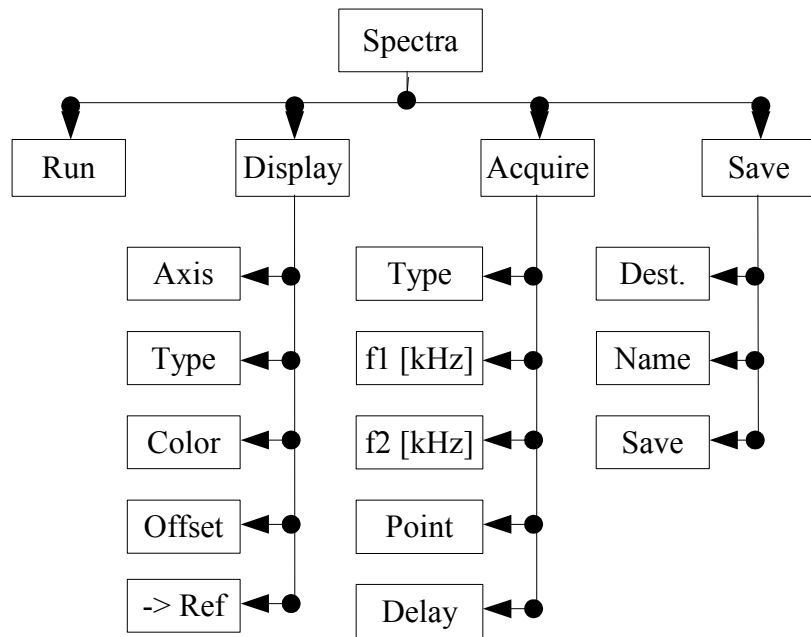

Figure 8: Menu structure of the Spectra mode.

The knobs **Measure** and **Setup** do not provide a deep menu structure. In order to understand the meaning of each entry in the menus, follow the manual structure starting with the **LockIn** menu in section .

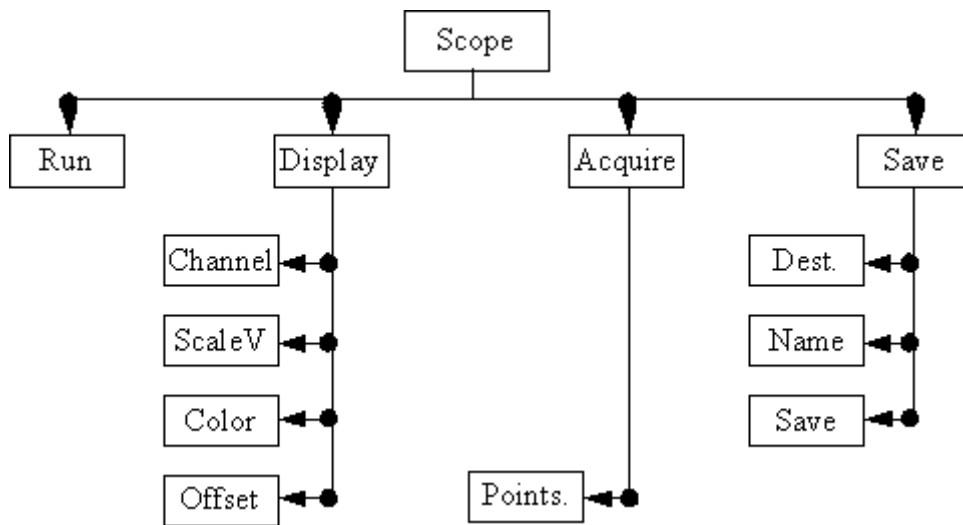

Figure 9: Oscilloscope menu called with the Scope button.

3.1.4 REAR PANEL

The back side panel provides

- SMB connectors for the internal D/A and A/D converters.
While all A/D-converters are available as data channel inside the instrument, only four of the D/A-converters provide a scaled output at the moment.

- SMB Ref-In connector for the reference input (PLL)
- SUB-D 15 connector for reference output (see Figure In the Appendix)
- USB and Network connector
- the 100 -240 V AC power supply (tested from minimum 70 V AC)

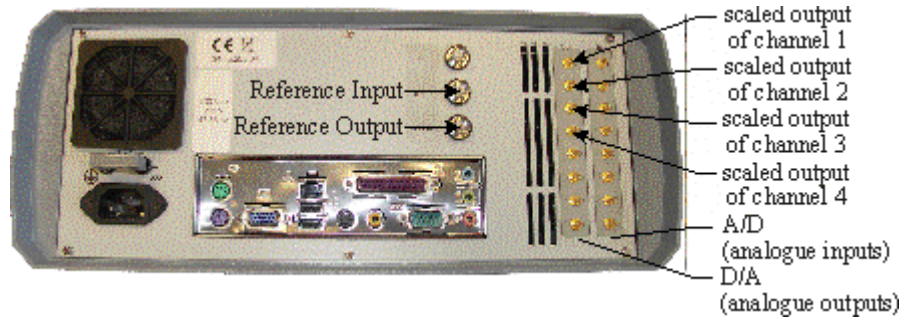

Figure 10: Rear-Panel of the **eLockIn** (picture might vary from current revisions). The ground connector above the power supply allows to separate the protective ground from the housing and thus increase the resistance between them to 1 MOhm.

3.2 THE LOCKIN MENU [[LOCKIN](#)]

3.2.1 INPUT SETTINGS [[LOCKIN / INPUT](#)]

Input Range [[LockIn / Input / Range](#)]

This setting changes the input amplification of the lock-in input stage by two hardware switches controllable from the software. These factors are according to the range value of "high dynamic reserve", "normal" and "low noise". Together with the input amplifications, dynamic range and sensitivity change. The lower the dynamic range, the higher the sensitivity is. The strategy for selecting a suitable **range** is: Choose the smallest value which is just bigger than the maximum input signal.

Example: When the maximum input signal is 300 mV_{pp}, the "low noise" input range will yield an overflow. The "normal" and "high dynamic reserve" input ranges are both possible, but the "normal" range gives the better sensitivity.

Note: If the Beep function [[Setup / Beep](#)] is enabled, the instrument beeps every time it detects an input overflow.

Input Coupling [[LockIn / Input / Couple](#)]

If the specification of the instrument allows it, this option switches between **DC** coupled input and **AC** coupled input.

Note: The 3dB corner frequency of the input high pass is around 2Hz. Reference frequencies around 2 Hz and below may cause misleading results.

Time Constant [[LockIn / Input / Time](#)]

This parameter is related to the low pass filters in the lock-in amplifier. It describes the 3dB-cut-off frequency f_c of the filter as:

$$\tau = \frac{1}{f_c}$$

τ might be defined as **time period** without synchronization to the period length related to the currently used as reference frequency. Then, the **eLockIn** integrates over the time τ . Alternatively, one might integrate over an integer number of periods synchronized to the current period length. This allows a time-optimized data acquisition at low frequencies. Starting from Software version 1.14, a further menu is entered at this point. It allows to switch between the time based and the synchronized integration mode as follows:

Enter Sync-mode: goto the **Sync** entry (2nd from the top) and turn the **knob** right or use **up**. The entry **Off** turns into a number (could be **1,2, ... , 200**), which is the amount of periods to be used for integration.

Leave Sync-Mode: goto the **Sync** entry and turn the **knob** left or use **down**, until the **number** turns into **Off**. Then, the previous time constants appear below the entries **Tau** and **Tau1**.

In time based mode, **Tau** equals the integration for channel A (**Input/Config** = **A&B**) or the n-th harmonic (**Input/Config** = **A** or **A-B**), while **Tau1** equals the integration for channel B (**Input/Config** = **A&B**) or the 1st harmonic (**Input/Config** = **A** or **A-B**). The two entries can be changed independently on each other.

In both entries **Tau** and **Tau1**, one can chose between a time (**0.1 ms, 0.2 ms, ... 500 s, 1 ks**) and a kind of frequency related integration (**10/f** and **100/f**). The later still uses the Butterworth filter, but choses the closest time constant for the currently selected frequency during spectra acquisition. This feature, however, is useful for noise measurements only, because the switching between different filter settings causes peaks in the acquired spectra. For the acquisition of spectra with varying integration adapted to the currently selected frequency, one has to enable the **Sync** filter. In this mode, the Butterworth filters are disabled and the **Slope** has no meaning anymore, which is displayed as **Sync** in the **Slope** menu entry.

For instruments with the LoL-Mode option, **Tau1** is used for the 2nd demodulation.



Time Constant [LockIn / Input / Time] → on a time base

Integration just on a timebase means that the time constant is not related to frequency at all. τ , the time constant, defines the length of the time interval taken into account for the low pass filtering. The **eLockn** employs a Butterworth-type low-pass filter. Together with the **Slope**, which is nothing else than the order of the low pass filter, the bandwidth and the raise time of the filters are given as follows:

<i>Roll-Off</i>	<i>Formula for bandwidth</i>	<i>Raise time / settled time to 90 %</i>	<i>Raise time / settled time to 99 %</i>	<i>Raise time / settled time to 99.9 %</i>	<i>Overshoot</i>
6 dB/oct	$\frac{\pi}{2\tau}$	0.43 τ	0.74 τ	1.11 τ	0,00 %

<i>Roll-Off</i>	<i>Formula for bandwidth</i>	<i>Raise time / settled time to 90 %</i>	<i>Raise time / settled time to 99 %</i>	<i>Raise time / settled time to 99.9 %</i>	<i>Overshoot</i>
12 dB/oct	$\frac{\pi}{2\sqrt{2}\tau}$	0.43 τ	0.52 τ / 1.05 τ	0.53 τ / 1.64 τ	4.32 %
24 dB/oct	$\frac{\pi}{8 \sin(\frac{\pi}{8})\tau}$	0.63 τ / 0.96 τ	0.70 τ / 1.66 τ	0.70 τ / 2.72 τ	10.8 %

The time constant can be set in logarithmic steps (1-2-5) between 0.1 ms and 1 ks.

Synchron Filter [LockIn / Input / Time] → synchronized integration

In synchronized low-pass filtering, the integration time is strictly connected to the current center frequency. It is given in multiples of 1/f and can vary between 1/f and 200/f.

The parameters "bandwidth" and "raise time" are not applicable for the synchronized filtering, anymore. The result is provided the moment it is valid. Thus, the oscilloscope might show staircase-like outputs for lower frequencies with accordingly high multiples of the period.

During spectra acquisition, the integration time is constantly adapted to the current frequency, so that the spectrum takes more time at low frequencies.

Roll-Off or Slope [LockIn / Input / Slope]

This parameter is related to the order of the low pass filter. We can select among 6 dB/oct, 12 dB/oct and 24 dB/oct. The 6 dB/oct selection equals a low pass filter slope of 1st order, while the 12 dB/oct and 24 dB/oct equal the 2nd and 4th order, respectively.

Config [LockIn / Input / Config]

This entry switches between the different input modes, if available from the model configuration.

<i>Mode</i>	<i>Description</i>
A	The input A is amplified in two different stages and given to the two ADC inputs of the digital lockin amplifier design, simultaneously. This reduces the noise. The 4-phase lockin evaluates two phases at the 1 st harmonic and two phases at any higher harmonic.
A-B <i>Models 203 and 204/2, only</i>	The two inputs A and B are amplified separately in a 1 st stage. Then, the difference between them is built electronically by a differential amplifier. The 2 nd amplification stage is applied to this difference and fed into the input ADC2. The lockin measures two phases at the 1 st harmonic and two phases at any higher harmonic.
A&B <i>Models 203 and 204/2, only</i>	The two inputs A and B are amplified separately and fed into the two inputs ADC1 and ADC2. One measures with two phases at the input A and with two further phases at the input B. Both inputs operated at the same frequency (1 st or higher harmonic) with the same input amplification (input gain).
I <i>current input</i>	Switches to the current input, if available . In this input type, only two amplification stages are available. Thus, 0.1 V and 1 V input range equal each other.

No matter which input mode is chosen, the **Time** Constant in [[LockIn / Input / Time](#)] and the **Slope** in [[LockIn / Input / Slope](#)] apply to all measured signals (all four phases).

3.2.2 REFERENCE OUTPUT [[LOCKIN / REF](#)]

The internal digital sine stream is built from a look-up table. The building process depends on three parameters: The main frequency, the phase and the harmonic. The generated reference output signal relates to this internal stream through these three parameters. In addition to that, the reference output has the amplitude as an independent parameter.

Reference Output Amplitude [[LockIn / Ref / Uac](#)]

The reference output is a sine signal. The parameter **Vac** is its RMS amplitude.

Reference Output Frequency [[LockIn / Ref / f \[Hz\]](#)]

The frequency selected here is the reference frequency f_{Ref} of the reference output and middle frequency of the lock-in amplifier. The analysis of the signal is done at the h^{th} of its harmonics f_m :

$$f_m = f_{Ref} h$$

Reference Output Phase [[LockIn / Ref / Phase](#)] → **phase**

Phase stands for the phase shift between the periodic excitation provided from the reference output or, in PLL mode, from the external trigger source and the detected oscillation at the input.

In case the harmonic **h** is equal to one, the number defined here is the phase difference between the reference output signal and the signal that is multiplied with the lock-in input. For higher harmonics, the a phase offset Φ is added to the detected signal.

AutoPhase – an automated phase detection – is implemented. Select the phase channel and use the [[Measure](#)] function to set the currently detected phase as phase offset.

Harmonic [[LockIn / Ref / Harm](#)]

This parameter indicates at which harmonic **h** of the reference frequency we measure.

PLL Input [[LockIn / Ref / RefIn](#)]

In order to use an external reference source, the **eLockIn** provides an internal PLL circuit. This circuit locks onto the external reference. One can switch the reference input between high signal amplitudes (LV-TTL) and low signal amplitudes (sine wave) with the switch [RefPLL](#) in [[Setup / MISC / RefPLL](#)].

This software knob [[RefIn](#)] switches the PLL **On** or **Off**. In case the reference input is **On**, the frequency in the parameter display shows the locking frequency as "PLL: **frequency-value**". In case the reference input is **Off**, the frequency value shown in the parameter display is the **frequency** of the internal reference.

3.2.3 DISPLAY SETTINGS [[LOCKIN / DISPLAY](#)]

In this sub-menu the user can choose which input signal should be displayed on the front panel. Moreover, the display sensitivity can be adapted separately for each input. At maximum the device can display four inputs. We refer to them as channels, however, they

can originate from at least 27 different sources:

- lock-in output channels – ***XA, YA, RA, ϕA*** (signals connected to the lock-in functionality detected at the n^{th} harmonic) → ***Group LIA n***
- lock-in input – ***In*** (signal taken directly from the front panel input) → ***Group Misc***
- lock-in settings – ***f*** (reference frequency of the lock-in amplifier), ***Uac*** (reference output amplitude) → ***Group Misc***
- A/D converter inputs – ***AD1, AD2, AD3, ... AD8*** → ***Group ADC***
- D/A converter inputs – ***DA1, DA2, DA3, ... DA8*** → ***Group DAC***
- quad-channel-LockIn output channels – ***XB, YB, RB, ϕB*** (if the ***eLockIn*** has the internal functionality of two different inputs) or ***XI, YI, RI, ϕI*** (if the ***eLockIn*** has one input only or its input setting is set to Input A, only) – in later case, the input signal is simultaneously characterized at the first and a higher harmonics.) → ***Group LIA 1***

In order to classify this large amount of selections, the channels are organized in the ***Groups: LIA n, Misc, ADC, DAC, LIA 1***. The ***Group “Off”*** stands for “no group” = “no signal”.

Channel [LockIn / Display / Channel]

In order to change the settings of the four channels, this button realizes the channel selection. All selections displayed in ***Group, Type*** and ***Range*** are valid on the selected channel only.

Group of Displayed Signal [LockIn / Display / Group]

The large amount of possible input signals is organized in ***Groups: LIA n, Misc, ADC, DAC, LIA 1***. The ***Group “Off”*** stands for “no group” = “no signal”.

Signal Source [LockIn / Display / Type]

The ***Type*** enables the source selection. All types described in are available on all four ***Channels***. The ***Sources*** selected in the first four channels are sent to the first four D/A outputs at the rear panel. In order to disable one channel, ***Off*** has to be selected.

Output Scaling [LockIn / Display / Range]

This parameter changes the display sensitivity, but not the measurement sensitivity. If the real value is bigger than the range, “***-ovld***” will be displayed. Simultaneously, it changes the scaling for the output amplitude sent to the D/A converters. The chosen sensitivity is related to the maximum output value of the D/A converter. which is 10 V. Thus the D/A output is scaled to this display range.

Example: If channel 1 displays the lock-in amplitude R and its range is set to 1 mV, a detected amplitude R of 1 mV gives an output value of 10 V at the DA1 (rear panel). If the signal shrinks to 1 μV , the output at the DA1 is only 10 mV. Because DA1 adds its own noise, its better to reduce the display range as much as useful to improve the output signal taken from the DA's at the rear panel.

3.2.4 AUX OUT [LockIn / Out]

In principle, this option allows to set the values provided at the eight output channels with 24 bit converters. With this, the implementation of feedback circuits for Kelvin Probe applications is prepared.

In the current instrument philosophy, the first four channels are always scaled with the display settings four the four channels. The AUX outputs AUX5 to AUX8 can be set to a certain voltage.

AUX Out Cannel [LockIn / Out / Channel]

This option selects the channel out of the eight AUX channels, for which the settings **Type** and **Value** are controlled here.

AUX Out Type [LockIn / Out / Type]

Set to **Scaled**, the related channels provides the output with respect to the setting given in [**LockIn / Display / Range**]. Set to **Const.**, a **value** can be set for the channel. In the current state, the channels DAC1 to DAC4 are automatically set to **Scaled**, while the channels DAC5 to DAC8 are set to **Const.**.

AUX Out Value [LockIn / Out / Value]

For the channels 5 to 8, a value given in V can be set here. In the remote control regime, this function can be used to control external parameters of a set-up and thus to program more enhanced measurement procedures.

3.3 THE SPECTRA MENU [SPECTRA]

While the **LockIn** mode displays values as numbers, the Spectra mode allows to collect such information in dependence on the frequency. The data are shown as graphs and can be saved as ASCII files for later analysis.

Note: The channels in spectra mode are the same as selected in the LockIn mode. The channel selection is only possible in LockIn mode (see on page).

In addition to the channels available in **LockIn** mode, the **Spectra** mode provides a reference channels **Ref**, which is used to store spectra temporarily.

Example: In order to measure a frequency spectrum of the amplitude R of an oscillating cantilever, take care that the following settings are correct:

- R is selected as source for channel 1 (),
- channel 1 is really displayed in a visible color (), and
- the display of the other three channels is disabled () to avoid confusion in the shown curves.

3.3.1 RUN/STOP [SPECTRA / RUN] OR [SPECTRA / STOP]

The first menu item in the menu toggles the state of the instrument in **Spectra** mode. To **Start** the spectrum acquisition, press button **1** (see Figure 5) when the node displays **Run**. To **Stop** the acquisition process, press **Stop**.

In order to acquire spectra in logarithmic steps, the **Type** of the frequency axis **freq** has to be set to **Log**.

3.3.2 DISPLAY [SPECTRA / DISPLAY]

In **Spectra** mode, the lines are superimposed on each others. The scaling on the screen is always automatically, which means they are scaled to fit the screen area independently on each other. The user can switch channels off (), control the color of each line and whether they are displayed linearly or logarithmic (). The line can be shifted by changing a parameter called offset ().

Axis [Spectra / Display / Axis]

This menu item gives access to the display parameters of all the selected channels (). Besides that, the parameters of one reference channel whose data are saved on the memory and the

frequency axis **freq** are available. When an axis is selected, its display parameters are shown in the lower nodes (**Type**, **Color**, and **Offset**).

Type [Spectra / Display / Type]

This menu item shows either the text **Lin** (linearly scaled) or **Log** (logarithmic scaled). If the selected axis is **freq** (frequency), this parameter equals also the sweeping type of the frequency.

Color [Spectra / Display / Color]

This menu item shows the color of the selected axis. If the **Color** is **Off** then the channel is not displayed. This menu item does not exist if the selected axis is **freq**.

Offset [Spectra / Display / Offset]

This shifts the selected curve along its axis. This menu item does not exist if the selected axis is **freq**.

Save Reference Channel [Spectra / Display / -> Ref]

If the reference channel is empty, **None** is displayed. Press once to store the data of the selected axis into the reference channel.

If the reference data set exists, the **name** of the stored channel is show and the reference data is displayed in the desired color.

3.3.3 ACQUIRE [SPECTRA / ACQUIRE]

For the spectrum acquisition, the following parameters can be set:

- start frequency **f1**
- stop frequency **f2**
- number of data **Points** in the spectrum
- acquisition **Delay** (is connected to the time constant)

Furthermore, there are several possibilities to handle spectra taken in sequence. Therefore we introduced a **Type** of spectrum acquisition, which allows to repeat acquisition or to sum up spectra.

Type [Spectra / Acquire / Type]

This parameter has three options:

- ◆ **Single**: The specified spectrum is acquired just once. When it is finished, the acquisition process stops.
- ◆ **Conti**.: which stands for continuously. The specified spectrum is acquired as long as **Run** is selected. When it is finished, the acquisition process restarts.
- ◆ **Integ**.: is an integrating acquisition of spectra. The spectra are taken continuously, however, the final spectrum is the average spectrum calculated from all taken spectra. The integration restarts with every **Run / Stop** selection.

f1 and f2 [Spectra / Acquire / f1] and [Spectra / Acquire / f2]

f1 = start frequency = first point in the spectrum.

f2 = stop frequency = last point in the spectrum.

Point [Spectra / Acquire / Point]

This is the number of points in the spectrum. The specific frequencies in the spectrum are calculated based on this number, **f1**, **f2** and the sweeping type ().

Delay [Spectra / Acquire / Delay]

This parameter controls the delay between the time when the instrument sets a new frequency and the time it takes the output data. Its length is given in multiples of **t**, the time constant (). In order to check useful values with respect to the settle time, refer to the table on page .

3.3.4 **SAVE [SPECTRA / SAVE]**

After the acquisition process finished, data can be saved to the hard disk or the USB flash drive for later analysis. The maximum volume of the hard disk for storing data is 32 megabytes. Up to 100 data files (i.e. **Dat1**, **Dat2**, .. **Dat100**) can be kept in the hard disk. If the USB flash drive is used, it should be compatible with the USB v1.1 specification. The USB flash drive should be formatted as FAT32.

Destination Storage Media [Spectra / Save / Dest.]

This parameter chooses the storage media to save the data to. The options are:

- **HD**: The data will be saved onto the internal hard disk.
- **USB** The data will be saved onto the USB flash drive.

If the hard disk is selected, the last-saved file name is displayed in the **Name** item. If that file is still in the memory, **Exist** will be displayed in the **Save** item. In case the file does not exist, **Empty** will be displayed in the **Save** item. When USB is selected, the instrument will check whether a working USB flash drive is connected in one of the USB connectors or not. If it finds one, the **Name** and **Save** items will be displayed in the same way as for the **HD**. If no USB flash drive is available or detected, **Error** will be displayed in the **Save** item.

Choose a File Name [Spectra / Save / Name]

The file name is not dependent on the storage medium. When a storage medium is selected, the directory **data** will be created in the root directory of the storage medium. The user can only choose from 100 predetermined names: **Dat1**, **Dat2**, ... , **Dat100**.

Save the File [Spectra / Save / Save]

When a valid storage device and a name is selected, the file can be saved. If the user select a file which already exists, it will be overwritten without notice. Just press button **3** (see Figure 5) next to the **Save** menu item to activate the action. If the file is successfully saved, the **Save** item will display **Saved!**, otherwise **Error** will be displayed (e.g. if the storage media is full).

3.4 **OSCILLOSCOPE [SCOPE]**

The input channels of the **eLockIn** are sampled with 40 kHz only, however, their display in an oscilloscope-like screen can be useful for some applications.

In **Spectra** mode, we acquire the spectra with respect to the frequency. The **Scope** mode allows to acquire the data with respect to the time. All available sources of data can be shown. Data shown on the oscilloscope screen can be saved for later analysis.

3.4.1 RUN/STOP [SCOPE / RUN] OR [SCOPE / STOP]

As in the *Spectra* mode, this menu item is just a switch between on and off state of the data acquisition in the oscilloscope. In the default state, the instrument waits for instructions and does not acquire data. Thus, *Run* is displayed and meant as instruction. To start the data acquisition press once. As long as oscilloscope data are acquired, this entry displays *Stop* as instruction.

3.4.2 DISPLAY [SCOPE / DISPLAY]

The display screen of the oscilloscope works like the display of the *Spectra* mode. All measured data are superimposed on each other.

The scale can be fixed or *auto*. If *auto* is selected, the screen is divided by 4 parts and channel *1..4* will be scaled to its full area (from top to bottom). The user can control the *Color* of each line. The lines can be shifted by changing the parameter *Offset*. The information area shows the displayed channels, their mean values and standard deviations.

Channel [Scope / Display / Channel]

The meaning of each channel, displayed as value under the channel number, is selected in *LockIn* mode. Here, the channels can only be selected. In addition, the time axis appears as channel. When a channel is selected, its display parameters are shown in the lower menu items (*ScaleV* or *ScaleH*, *Color*, *Offset*).

Scale [Scope / Display / Scale]

For Time axis, this menu item is called *ScaleH*. For the other channels, its name is *ScaleV*. All channels use the same time axis. This node shows the display scale of the selected channel. The units are dependent on the source of the channel and counted in divisions of the screen. In order to fit the channel in its display area, choose *auto*.

Color [Scope / Display / Color]

= *Color* of the selected channel. If *Off* is selected, the channel is not visible.

Offset [Scope / Display / Offset]

= vertical *Offset* value for the display of the channels. This node does not exist, if the selected axis is *Time*.

3.4.3 ACQUIRE [SCOPE / ACQUIRE]

Points [Scope / Acquire / Points]

this entry allows to set the number of data *points* in the menu oscilloscope.

3.4.4 SAVE [SCOPE / SAVE]

The user is referred to for details on saving on HD or USB space.

In addition to the locations USB and HD, the oscilloscope allows to save the data into the WEB-space. The user can get the data via webbrowser inside the directory as shown in the picture.

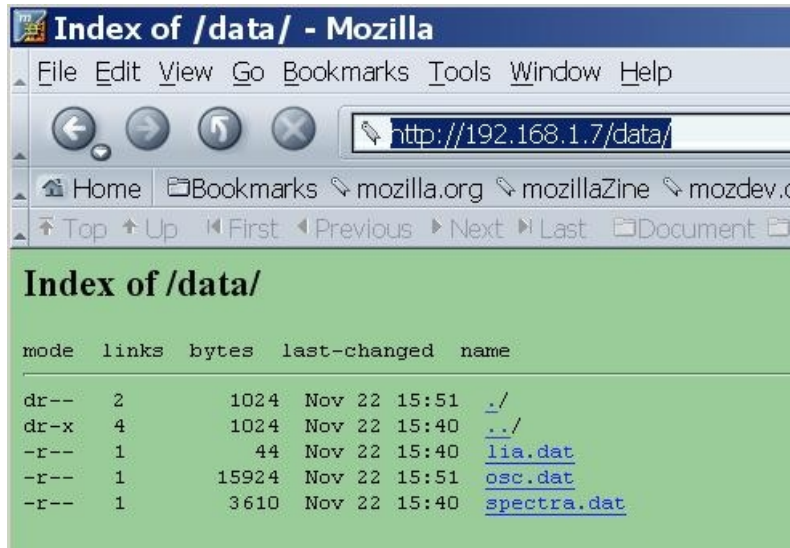

3.5 MEASURE [MEASURE]

Measure is intended to simplify procedures. Up to now, this function is only valid if a spectrum is obtained, stopped and visible on the screen.

Calling **Measure** adds a cursor to the selected curve. You can shift the cursor along the curve

with the **Knob**. Notice that the reference frequency shifts together with the cursor position. When you go back to [LockIn], the selected frequency is kept and you can change time constant or excitation amplitude.

In addition, the Q-factor of detected resonances is calculated and displayed.

You have measured a resonance curve in spectra mode. At the end, the reference frequency sets to the default value automatically. Now switch to Measure and shift the cursor to the position you like to use for the excitation. This changes the default reference frequency.

Note: The cursor appears on the last selected data set out of the four display channels. No cursor will appear if another channel is selected in [Spectra / Display] or the signal is switched to invisible (Color = Off).

3.6 SETUP [SETUP]

The main screen in the **Setup** mode displays certain system parameters as free RAM space, free disk space and so on. The menu entries have the following functions:

- **Config IP**: The IP address, which is necessary to control the instrument over the LAN, can be changed here. **DHCP** can be enabled. In order to ake any change of the IP address over or if the DHCP client is enabled or disabled, one has to confirm the changes with **Save**.
- **Misc** – opens a sub-menu with the following entries:
 - ◆ **Beep (On / Off)**: This beep can help to identify a range overflow of the input channel.
 - ◆ **TimeOut**: The time given here is related to an internal timer and connected to several time-dependent functions:
 - ☑ This time multiplied by 1000 gives the time, after which the instrument stores the parameters automatically.
 - ☑ This multiplied by 10 gives the screen update rate of the **LockIn** and the oscillo**Scope** screen.
 - ☑ This time multiplied by 10 gives the screen update rate during spectrum acquisition.
 - ◆ **RefPLL**: selects the reference level for the PLL input. If **High**, the input level is expected to be a LV-TTL signal, because the switching level for a LV-TLL signal is 1.5 V. CMOS-TTL works as well. If **Low**, the PLL input can be sinusoidal wave with 100 mVpp minimum amplitude, which oscillates around

zero.

- **Green** – opens a sub-menu. The entries in this menu are not stored. After restart, the brightness will be set to its full intensity and the auxiliary channels will be on ON state. Entries:
 - ◆ **Aux** (**On / Off**): switches the power supply of the analogue input and output channels on or off.
 - ◆ **Display**: is the brightness of the screen. 15 equals maximum and 0 switches it off.
- **HD**: Enters a sub-menu in which the data files stored on the internal hard disk can be
 - copied to the USB flash drive by **> USB (Do)** or
 - deleted all by **Clear. (Do)**
- **Update (?)**: The **eLockIn** software can be updated with this function. Store the update files on a USB flash drive in a directory called "update" (case sensitive) and plug it into the front panel USB connector. Click on the **Update** button to start the update. The main screen will display messages about the updated files and the update success. To activate the new files switch the device off, wait a second and switch on again.

3.7 HANDLING OF PARAMETER SETTINGS

The settings done on the device are stored in a file. However, this storage is only done, if the **eLockIn** hasn't got new inputs for more than 10 seconds (**TimeOut** = 10 ms, see). If you like to switch off the device and find it back in the same state after switching on again, just do not press any button for 10 seconds before you switch off.

In case a parameter setting is not found back or the parameter file is damaged, **eLockIn** uses default settings.

3.8 FTP DATA ACCESS

Currently, ftp access exists only for the "**root**" user. As root, one has all rights and the password is even not sent encrypted over the network. **THIS ACCESS can be DANGEROUS!**

The easiest way to use ftp-access is by a **Web browser**. Type in the path: "**ftp://root@[IP address]**" (e.g. if the IP address of the device is set to "192.168.1.7" then type "**ftp://root@192.168.1.7**"). Stored data files are located on the hard disk at "**ftp://root@[IP address]/d/data**".

User name: root
Default-Password: eLockIn (!! case sensitive !!)

How to change the root password? Create a file called "root.pwd" in a directory "update" on a USB flash drive. Inside this file, write the password as clear ASCII data. Plug the USB flash drive in the front slot and "update". The password is coded internally and stored. After the next restart, the **eLockIn** can be accessed with the new root-password.

3.9 HTTP WEB ACCESS

Standard access via web browser uses "**http://[IP address]**". The "**Log in**" window appears:



User name: long
Password: nga

3.10 KNOWN PROBLEMS

One error might occur if USB flash drives are used. This error is caused by a problem in the linux operation system. It is not able to mount all types of USB flash drives. When a certain type was mounted, mounting another type might require a restart of the **eLockIn**.

4 REMOTE CONTROL

– Controlling your eLockIn via network –

4.1 ACCESSING THE eLOCKIN USING THE CGI INTERFACE

Communication between the remote computer and the eLockIn is based on TCP (Transmission Control Protocol) and http (Hypertext Transfer Protocol) for transferring HTML files and pictures.

Interaction with the *eLockIn* is mainly done by calling [Common Gateway Interface \(CGI\)](#) programs, which are executable programs called by the web server when it receives a request for one of them. CGI files may take parameters and values as arguments, passed to them as a string appended after a '?' (question mark) and separated by '&' (ampersand).

```
/cgi-bin/example.cgi?parameter1=abc&parameter2=123
```

Note: Items that are residing on the *eLockIn*'s web server are only accessible after successful authentication! Files on the web server will be denoted as follows:

```
/directory/filename
```

This means that the file 'filename' can be found in subdirectory 'directory' in the web server's main directory. In a web browser, this file could be accessed by entering

```
192.168.1.7/directory/filename
```

into the address bar. '192.168.1.7' would be your *eLockIn*'s IP address.

The main elements of control are:

- ***/cgi-bin/remote.cgi***, which accepts key codes and passes them to the *eLockIn* software,
- ***/cgi-bin/refresh.cgi***, which sends an HTML page containing current channel values
- ***/screen.jpg*** an image of the *eLockIn*'s display, stored as a JPEG picture,
- a textfile ***/lia.dat***, which contains the current values of the *eLockIn*'s channels 1 to 4.

4.1.1 REQUIREMENTS

Both the *eLockIn* and the remote computer must be connected to a network. This could be a simple crosslink cable between the two devices, a LAN (Local Area Network) or even the internet.

On start-up, the *eLockIn* will set its IP address to a default value, which can be changed in the **Setup** menu. You have to know this IP address to connect to the *eLockIn*.

4.1.2 AUTHENTICATION

Before the *eLockIn* can be remote-controlled, the user has to provide a user name and a password. This can either be done by entering the *eLockIn*'s IP address in a web browser and filling in the authorization form, or by calling ***/cgi-bin/login.cgi*** directly. *login.cgi* takes a string as argument: ?username=<user>&password=<pass>

<user> denotes the user name and <pass> the corresponding password.
Thus, the following http request would authenticate user 'long' by sending his password 'nga':

```
http://192.168.1.7/cgi-bin/login.cgi?username=long  
&password=nga HTTP/1.0
```

or

```
GET /cgi-bin/login.cgi?username=long&password=nga  
HTTP/1.0
```

Note: After the 'GET'-line, there must be *two* line delimiters, either <CRLF><CRLF> or <LF><LF>! Otherwise, the request will probably not be processed by the server.

4.1.3 SENDING KEY CODES TO THE eLOCKIN

A program named remote.cgi will be called by the **eLockIn**'s web server when it receives a request for **/cgi-bin/remote.cgi**.

Let's assume a TCP connection has already been established between the remote computer and the **eLockIn** on port 80 (default for http connections) and the user has identified himself as described in the 'Authentication' section .

If that is the case, commands can be sent to the **eLockIn** device by requesting **/cgi-bin/remote.cgi** via http and passing keys as arguments to it. Those keys are treated the same way as if they were pressed on the **eLockIn** itself. A typical http request would look like the following:

```
http://192.168.1.7/cgi-bin/remote.cgi?S_6_8 HTTP/1.0
```

or

```
GET /cgi-bin/remote.cgi?S_6_8 HTTP/1.0
```

The request shown above would cause the **eLockIn** to

- dump a screenshot of the display to /screen.jpg ('S'),
- enter the number '6' at the position that is currently focused on the display ('_6_', underscores enclose numbers),
- switch to the **eLockIn** menu ('8').

For a complete list of the commands that can be sent to remote.cgi, see Table 1 or Figure 11.

All of these keys except 'S' correspond to buttons on the front panel of the **eLockIn** (see Figure 11). Therefore the **eLockIn** can be remote-controlled in the same way as if it is operated manually.

<i>Key (char)</i>	<i>ASCII Code</i>	<i>Action</i>
8	56	Enter LockIn menu
C	67	Enter Spectra menu
4	52	Enter Scope menu
F	70	Enter Measure menu
0	48	Enter Setup menu
9	57	These buttons invoke the action displayed next to them on the screen, depending on the current position in the menu tree.
D	68	
5	53	
1	49	
7	55	Go back in menu
B	66	Up
E	69	Down
6	54	Left
2	50	Right
+	43	Knob Right
-	45	Knob Left
S	83	Save screenshot

Table 1: Command keys

Specific values can be adjusted either by using buttons or by sending numbers to the **eLockIn**. The device accepts numbers wherever the software expects user input. Just like the other commands, numbers need to be passed to '/cgi-bin/remote.cgi', but have to be enclosed by '_' (underscore).

```
http://192.168.1.7/cgi-bin/remote.cgi?8DD_100000_8
or
GET 192.168.1.7/cgi-bin/remote.cgi?8DD_100000_8
```

The command sequence shown above tells the **eLockIn** to

- switch to 'LockIn' menu ('8')
- enter 'Ref' submenu ('D')
- adjust frequency ('D')
- set frequency to 100 kHz ('_100000_') !! the second "_" is required even if there is no further menu entry.
- return to 'LockIn' main menu ('8')

4.1.4 SETTING VALUES

At some menu positions, the **eLockIn** require special numerical values which correspond

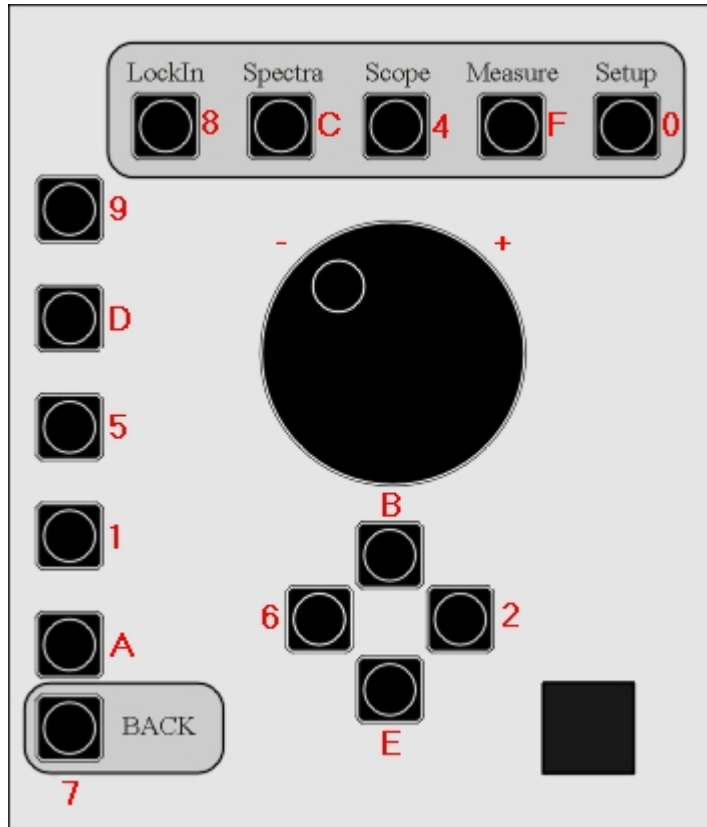

Figure 11: Keys and corresponding buttons

to the values that will be set. The following tables show the respective numbers/values at different menu positions.

Number	Value
1	"low noise"
10	"normal"
100	"high dyn. reserve"

Table 2: Menu-Entry: **LockIn-Input-Range**
lockin.ini entry: `InputRange`

Key Code: 899_??_

Number	Value
0	dc coupled
1	ac coupled

Table 3: Menu-Entry: **LockIn-Input-Couple**
lockin.ini entry: `InputCouple`

Key Code: 89D_??_

Number	Value
6	6dB/oct
12	12dB/oct
24	24dB/oct

Table 4: Menu-Entry: **LockIn-Input-Slope**
lockin.ini entries: `Rolloff` and `RolloffLoL`

These two entries in the lockin.ini file equal each other. **Key Code: 891_??_**

Number	Value
0	"A"
1	"A-B"
2	"A&B"

Table 5: Menu-Entry: **LockIn-Input-Config**
lockin.ini entry: `InputMode`

Key Code: 89A_??_

Number	Value
0	"Off"
1	1/f
2	2/f
5	5/f
⋮	⋮
⋮	⋮
200	200/f

Table 6: Menu-Entry: **LockIn-Input-Time-Sync**

lockin.ini entry: `Sync0` and `SyncLoL`

These two entries in the lockin.ini file equal each other. **Key code: 895D_??_**

Number	Value
0	0.1ms
1	0.2ms
2	0.5ms
3	1ms
4	2ms
5	5ms
6	10ms
7	20ms
8	50ms
9	100ms
10	200ms
11	500ms
12	1s
13	2s
14	5s
15	10s
16	20s
17	50s
18	100s
19	200s
20	500s
21	1ks

Table 7: Menu-Entry: **LockIn-Input-Time-Tau** and **LockIn-Input-Time-Tau1**

lockin.ini entry: `InputMode`

Key code: 895D_0_9_??_ or 895D_0_5_??_

Number	Value
0 or 1	1 st harmonic
2	2 nd harmonic
:	:
15	15 th harmonic

Table 8: Menu-Entry: **LockIn-Ref-Harm**

lockin.ini entry: `Harmonic`

Key code: 8D1_??_

Number	Value
0	RefIn = OFF
1	RefIn = ON

Table 9: Menu-Entry: **LockIn-Ref-RefIn**

lockin.ini entry: `InputCouple` **8DA_??_**

Number	Value
0	"Freq"
1..4	Ch1 .. Ch1

Table 10: Menu-Entry: **Spectra-Display-Axis**

Key code: CD9_??_

Number	Value
0	"lin"
1	"log"

Table 11: Menu-Entry: **Spectra-Display-Type**

Key code: CD9_Channel_D_??_

Number	Value
Any integer number	"Freq"
1..4	Ch1 .. Ch1

Table 12: Menu-Entry: **Spectra-Display-Offset**

Key code: CD9_Channel_1_??_

<i>Number</i>	<i>Value</i>
1	White
2	Yellow
3	Blue
4	Green
5	Red
6	Cyan
7	Magenta
8	Gray
9	Brown
10-15	White

Table 13: Colors in **Spectra-Display-Color** and in **Scope-Display-Color**.
Key code: **CD9_Channel_5_??_**

<i>Number</i>	<i>Value</i>
0	Single
1	Conti.
2	Integ.

Table 14: Menu-Entry: **Spectra-Acquire-Type**
Key code: **C59_??_**

<i>Number</i>	<i>Value</i>
0	0.01*T
1	0.1*T
2	0.2*T
3	0.5*T
4	1*T
5	2*T
6	5*T

Table 15: Menu-Entry: **Spectra-Acquire-Delay**
Key code: **C5A_??_**

<i>Number</i>	<i>Value</i>
3	10 mV
4	100 mV
5	1 V
6	10 V

Table 16: Scaling for analogue output channels and the display, Menu Entry: **LockIn-Display** for the signals AD1 to AD8
Key code: **859_channel_1_??_**

<i>Number</i>	<i>Value</i>
100	10 nV
101	20 nV
102	50 nV
103	100 nV
104	200 nV
105	500 nV
106	1 μ V
107	2 μ V
108	5 μ V
109	10 μ V
110	20 μ V
111	50 μ V
112	100 μ V
113	200 μ V
114	500 μ V
115	1 mV
116	2 mV
117	5 mV
118	10 mV
119	20 mV
120	50 mV
121	100 mV
122	200 mV
123	500 mV
124	1 V
125	2 V
126	5 V
127	10 V

Table 17: Display Scaling for analogue output channels and the display, Menu-Entry: **LockIn-Display** for the signals XA, YA, RA, XB, YB, and RB. lockin.ini entry: **Channel1Range ... Channel14Range**
Key code: **859_Channel_1_??_**

<i>Number</i>	<i>Value</i>
0	1μV
1	2μV
2	5μV
3	10μV
4	20μV
5	50μV
6	100μV
7	200μV
8	500μV
9	1mV
10	2mV
11	5mV
12	10mV
13	20mV
14	50mV
15	100mV
16	200mV
17	500mV
18	1V
19	2V
20	5V
21	10V
22	20V
23	50V
24	auto

Table 18: Menu-Entry: **Scope-Display-Scale**

Key Code: 4D9_Channel_D_??_ (this does not work, when the channel displays a phase signal or other special signals)

4.1.5 RETRIEVING SCREENSHOTS

After receiving the 'S' command, the **eLockIn** will save its current display content as a JPEG image in '/screen.jpg'. Then it can be retrieved by a web browser or a similar program such as the Delphi example shipped with the **eLockIn**.

4.1.6 RETRIEVING CHANNEL VALUES

If you are interested in obtaining actual channel values, you can either use the HTML file sent by /cgi-bin/refresh.cgi or the text file /lia.dat. To extract pure data from refresh.cgi's answer, surrounding HTML tags have to be cut away. On the other hand, lia.dat provides pure numbers and is faster.

<i>Number</i>	<i>Value</i>
0	1μs
1	2μs
2	5μs
3	10us
4	20us
5	50μs
6	100μs
7	200μs
8	500μs
9	1ms
10	2ms
11	5ms
12	10ms
13	20ms
14	50ms
15	100ms
16	200ms
17	500ms
18	1s
19	2s
20	5s

Table 19: Menu-Entry: **Scope-Display-Channel[Time]-ScaleH**

Key Code: 4D9_0_D_??_

4.1.7 GET INTERNAL SETTINGS AND STATUS INFORMATION

The current settings of the **eLockIn** are stored in a file `./setup/lockin.ini`, which is available through the web-interface:

<http://192.168.1.7/setup/lockin.ini>

This file contains:

```
Amplitude: 0.0200
Frequency: 1001.00
Timeconstant: 9
Rolloff: 24
InputRange: 1
Phase: 10.0
Harmonic: 1
AmplCaretPos: 3
FreqCaretPos: 4
FreqCaretPosTail: 2
PhaseCaretPos: 5
DisplayChannel: 2
Channel1Type: 3
Channel1Range: 120
Channel2Type: 4
Channel2Range: 7
Channel3Type: 26
Channel3Range: 120
Channel4Type: 27
Channel4Range: 7
InputCouple: 0
InputMode: 2
RefInFlag: 0
TimeConstLoL: 6
RollOffLoL: 24
SyncLoL: 0
Sync0: 0
Phase0: 0.0
EndOK
```

Frequency and amplitude are given as values in Hz and in V, respectively, while the phase is shown in degree. All other data are stored in the numeric code provided in the tables 2 through 9 on the pages 33 to 34.

Additionally, the state of the internal overload is provided by sending:

<http://192.168.1.7/cgi-bin/remote.cgi>

As result, the eLockin sends

"idle 0"	if no overload is active
"idle 1"	if the frequency range is exceeded (blue exclamation mark)
"idle 2"	if the AD-converter input is in overlaod (red exclamation mark)
"idle 3"	if both overload states are active.

4.1.8 EXAMPLE PROGRAM: LOCKINREMOTE

LockInRemote is an example program written in Borland Delphi 6 and designed to show the possibilities of remote-controlling an **eLockIn**. Its graphical user interface (GUI) looks similar to the front panel and each button works the same way the real one does.

LockInRemote uses a TClientSocket object to set up a TCP connection to the **eLockIn**,

working in non-blocking mode.

After starting the program, the screen will still be empty, because authentication is required first. Click **LockIn**→**Authenticate** to open the authentication menu. Enter your user name, password and the *eLockIn*'s IP and click '**Connect**'. If the *eLockIn* is found and your authentication data are valid, you will be logged in.

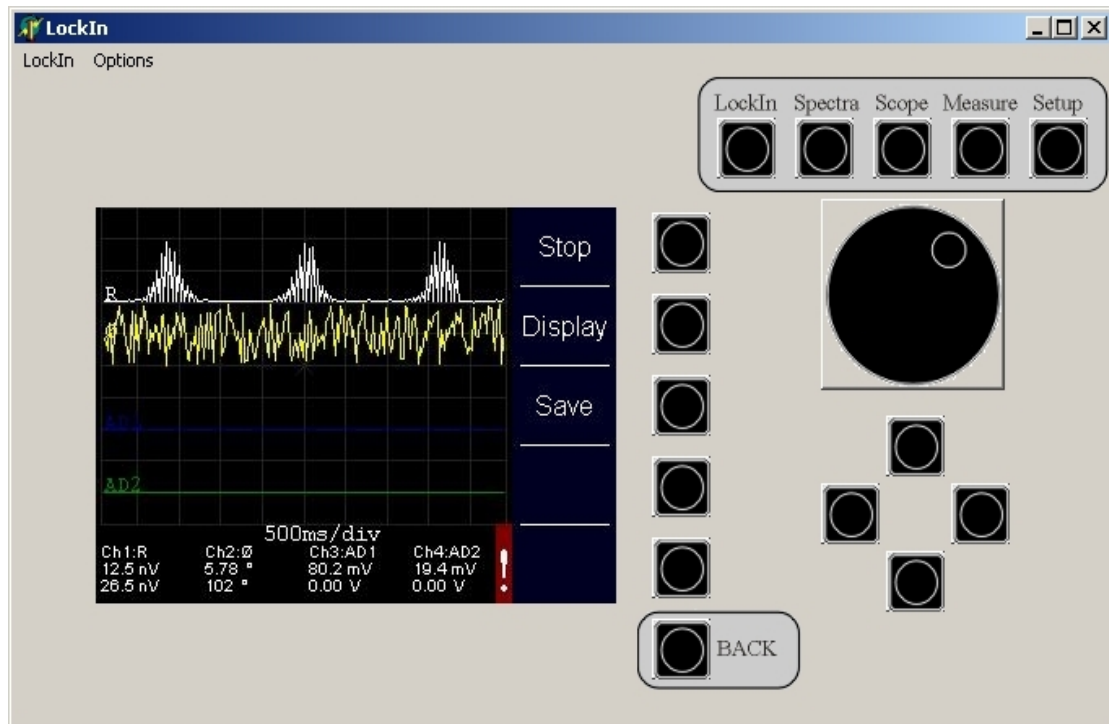

Figure 12: LockInRemote program surface.

Now you may want to select '**Auto Refresh...**' from the '**Options**' menu in order to choose how the *eLockIn*'s data should be presented:

- Auto-Refresh Screen causes the program to retrieve a new screenshot continuously. This is useful if you want to navigate through the menu tree.
- Auto-Refresh Channel displays current channel data
- Auto-Refresh Off disables Auto-Refresh

It is possible to get new screen/channel data by refreshing them manually as well.

The '**Options**' menu also offers a simple speed test. Click '**Test Speed**' to check the abilities of your network connection. Choose a number and click '**Test**'. The same picture will be retrieved *n* times from the *eLockIn*, while time is measured. Later, speed and time per picture will be displayed.

All the buttons on the right side of the panel have the same functionality as their counterparts on the *eLockIn*. The row of buttons next to the screen represents different meanings, depending on which option is currently assigned to them on the display.

If you need to pass parameters to the *eLockIn*, choose '**Set Value**' from the '**LockIn**' menu. Enter parameters/values as described above (no underscores needed here!).

4.2 USE CGI-FUNCTIONS VIA WEB BROWSER

Web browsers are also able to address the CGI-interface of the **eLockIn** directly. The commands are based on the structure described in the previous chapter. The only difference is that the web browser needs the IP-address of the **eLockIn** for every command.

Example: Set the reference frequency to 100 kHz using the **remote.cgi** with the following parameter set:

http://192.168.1.7/cgi-bin/remote.cgi?8DD_100000_8

After '?', '8DD' indicates that the 'LockIn', the 'Ref' and the 'f [kHz]' menus are entered one after the other. The underscore is the spacer for the frequency value '100000'. With the '8' command, the **eLockIn** is turned back to the 'LockIn' main menu.

4.3 EXPORTED FUNCTIONS OF THE ELOCKIN.DLL

The functions exported by the dll are described in the following table.

Name	Input	Output	Description
_Init	IP-address type: pChar	No Return value.	Initializes the eLockIn by calling the current IP address.
_GetLockInData	Channel [1 to 4] type: Integer	Value [real number] type: double	Returns the measured <i>Value</i> of the <i>Channel</i> as real number. ***
_SetLockInInpRange	Range type: double	No Return value.	Switches the input range between low noise (1), normal (10) and high dynamic reserve (100) (see table 2 page 33).
_SetLockInCouple	Couple type: double	No Return value.	Switches the input coupling between dc (0) and ac (1).
_SetLockInFilterTime	Time constant type: double	No Return value.	Switches the time constant of the filter. The values are coded as in table 3 on page 33.
_SetLockInFilterSlope	Filter Slope type: double	No Return value.	Switches the rol-off of the filter. The values are coded as in table 4 on page 33.
_SetLockInUac	Uac type: double	No Return value.	Sets the amplitude of the reference output to a values given as double.
_SetLockInFreq	Frequency type: double	No Return value.	Sets the frequency of the reference output to a values given as double.
_SetLockInPhase	Phase type: double	No Return value.	Sets the phase offset of the internal oscillator with respect to the analyzed signal. The values are given as double.

_SetLockInHarm	Harmonic type: double	No value.	Return	Sets the harmonic at which the signal is analyzed. The values are given as double.
_SetLockInAuxOut	Channel: [4 to 7] Data: type: double	No value	Return	Sets the auxiliary output channels 5 to 8. Channel = 4 equals „DA5“ at the backpanel of the <i>eLockIn</i> .

*** In order to obtain values from channel 2 to 4, one has to call channel 1 first, because the channels 2 to 4 are not taken directly from the *eLockIn* via TCP/IP. When calling „__GetLockInData“ for channel 1, the data of the other three channels simultaneously are transferred and stored locally in the memory. A subsequent call of „__GetLockInData“ for the channels 2 to 4 takes the values from the memory, only.

4.4 REMOTE CONTROL FOR THE eLOCKIN IN LABVIEW

For the remote control of the *eLockIn* under LabView, one can use the DLL-functions or one can address the *eLockIn* via TCP/IP communication. For the DLL based access, the following programs are provided:

- eLockin.dll provides the interface function
- eLockin.vi communication main program, which starts the
- Get_eLockin.vi and uses the Get_eLockin.vi and the Ref_eLockin.vi
- Ref_eLockin.vi data interface, which takes the data from the
- TestAuxOut.vi settings of the reference output
- TestAuxOut.vi example for the AuxOut usage

All programs should be in the same program directory.
For the TCP/IP access, the program tcpip.vi is provided.

4.4.1 TCP/IP ACCESS BY LABVIEW

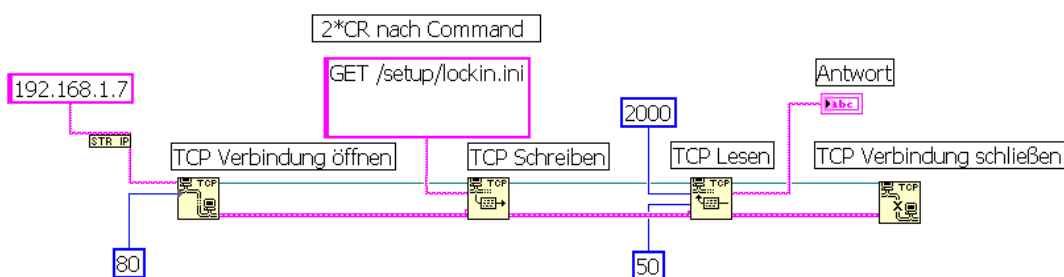

„TCP Open Connection“ == „TCP Verbindung öffnen“

inputs:

IP address of the eLockIn device --> purple --> 192.168.1.7
 Communication port --> blue --> 80

outputs:

Connection ID output --> thin green
 Error Output (Fehlerausgang) --> fat purple

„TCP Write“ == „TCP Schreiben“

inputs:

Connection ID --> thin green
Error input --> fat purple
Data input --> thin purple
--> „GET

/setup/lockin.ini CR CR

outputs:

Connection ID output --> thin green
Error Output (Fehlerausgang) --> fat purple

„TCP Read“ == „TCP Lesen“

inputs:

Connection ID --> thin green
Error input --> fat purple
Bytes to read --> blue --> 2000
Timeout in ms --> blue
--> 50

outputs:

Connection ID output --> thin green
Data Output --> thin purple (String) -->
displayed in screen
Error Output (Fehlerausgang) --> fat purple

„TCP Connection Close“ == „TCP Verbindung schließen“

inputs:

Connection ID --> thin green
Error input --> fat purple

Answers from the eLockIn:

Result for „GET /setup/lockin.ini CR CR“

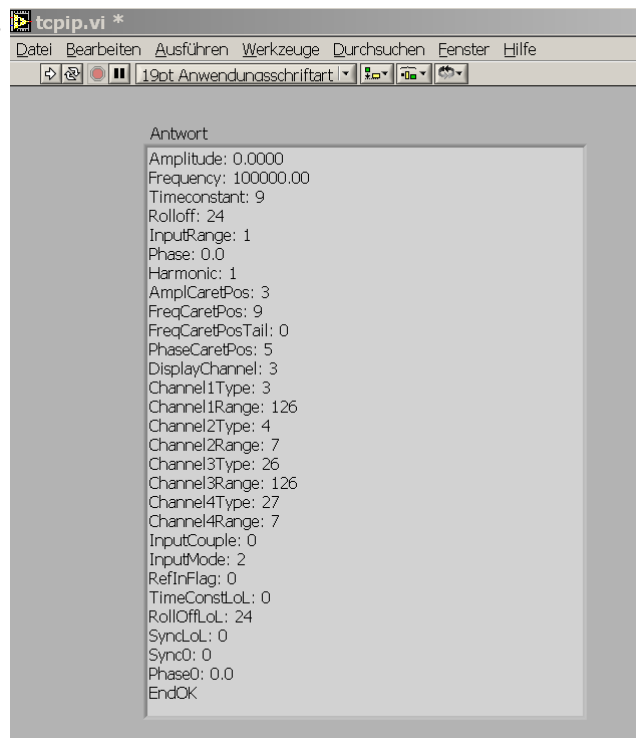

Result for „GET /setup/lockin.ini CR CR“

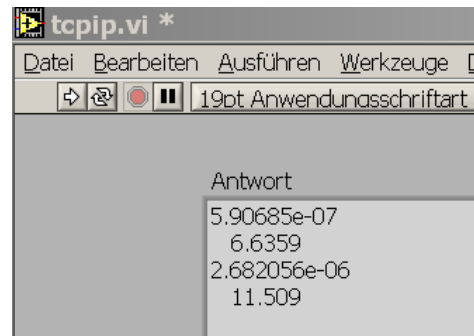

4.4.2 DLL BASED ACCESS BY LABVIEW

eLockin.vi hierarchie

The main program eLockin.vi contains a sequence in three steps and calls two sub-VI's: Ref_eLockin.vi and Get_eLockin.vi.

During run, it calls a three-step sequence:

- **Step 0:** eLockin.vi starts the communication with the lockin. The IP address is a value entry in the diagram used as input for the library function call „__Init“. Then, the system waits for 500 ms to let the *eLockIn* initialize.
- **Step 1:** The Sub-VI „Ref_eLockin.vi“ is called to set reference voltage and reference frequency. The other two functions of this Sub-VI, phase and harmonic, are not used here.
- **Step 2:** A curve diagram is drawn with 100 values, which are taken from the Sub-VI „Get_eLockin.vi“, which uses the function call of „__GetLockInData2 for the channel number 1. Between the single data, 100 ms delay time is given.

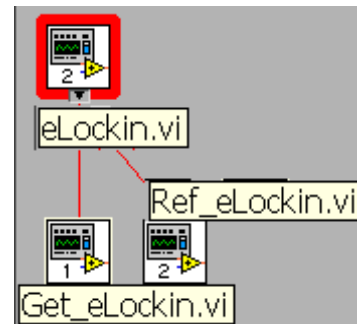



The example does not use all provided DLL-functions, but it shows how to implement them in own applications.

Usage of the LabView control

To start LabView, double-click on the icon or program eLockin.vi.

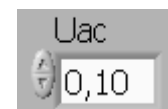
The main program shows a curve diagram and two input windows for the reference amplitude and reference frequency:



The entered values are overtaken, when the start knob  is applied. The same knob starts the acquisition of data in the curve diagram for one time cycle.

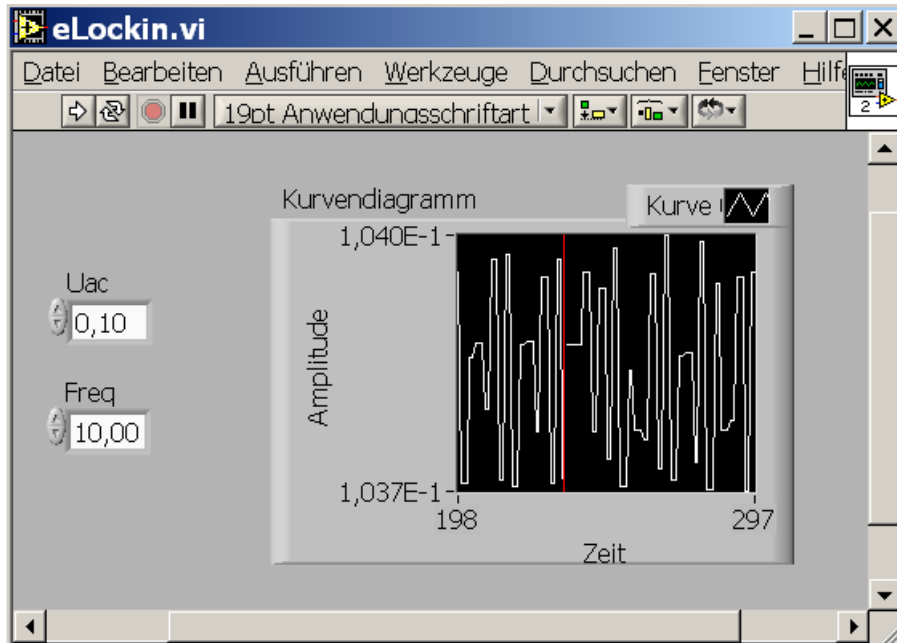

TestAuxOut.vi

This is an additional example program, which shows how to use the function „_SetLockInAuxOut“. The number taken as „Channel“ are counted from zero, while the labeling at the backside of the instrument count the AuxOut-Pins from One. Therefore, the 5th output named „DA5“ in the software is addressed from Channel = 4.

Remark: In order to check your settings, use [LockIn/Display/..] to set one out of the four lockin displays to the addressed channel (e.g. „DA5“).

5 SOFTWARE-UPDATE

CAUTION: The software update of the *eLockIn* can be compared with a **BIOS update** of a PC. One should spare the same caution. A power failure or power blackout during this procedure might cause a system crash, after which the *eLockIn* software needs to be restored in our facilities. **When this procedure fails, the instrument has to be shipped to us!**

If all precautions against power failure are done, follow these steps:

- ◆ Unpack the software update.
- ◆ Create a directory "update" (case-sensitive!) in the root on a USB stick.
- ◆ Copy all data into this directory.
- ◆ Plug the USB-Stick in the front panel of the eLockIn20-dual and wait a few seconds.
- ◆ Chose "SETUP". Press the knob besides "UPDATE". The update starts. The eLockIn204/2 displays all files which are uploaded from the stick in a list.
- ◆ The update is completed, if it displays "DONE".
- ◆ Switch the *eLockIn* OFF and wait for at least 5 to 10 s.
- ◆ Switch the instrument ON again. The new software should run.

6 REVISION HISTORY

This section tracks changes in the specification of the *eLockIn*, its software, hardware or its manual.

6.1 MANUAL REVISIONS

None. Latest specification revision: 12.12.2009.

6.2 HARDWARE REVISIONS

The current hardware version is HW26. The standard input of the current hardware is Revision "829" scaled and calibrated till 1 MHz.

6.3 SOFTWARE REVISION

The current software version is 1.14 with the following changes:

- the *eLockIn* shows a boot image when it boots and the boot time has been reduced
- Selecting a menu entry does not result in an immediate change of the currently set value (example: switching between ac coupling and dc coupling)
- Separate menu for the setting of the time constant / synchronized mode
- Time constants for the two 2-phase paths in the internal design can be set
- Separate entry for the setting of phase shifts
- Phase offsets for the two inputs can be set independently
- AutoPhase function implemented
- The speed of the knob turn has been limited, so that too fast changes of parameters are limited
- "eLockIn goes Green" → the brightness of the display can be reduced in 15 steps to almost zero and the power supply of the analogue inputs and outputs can be switched off.
- Faster access to data through the TCP/IP interface
- DHCP client integrated

7 APPENDICES

7.1 SCHEMATIC DIAGRAM OF THE SIGNAL PATHS

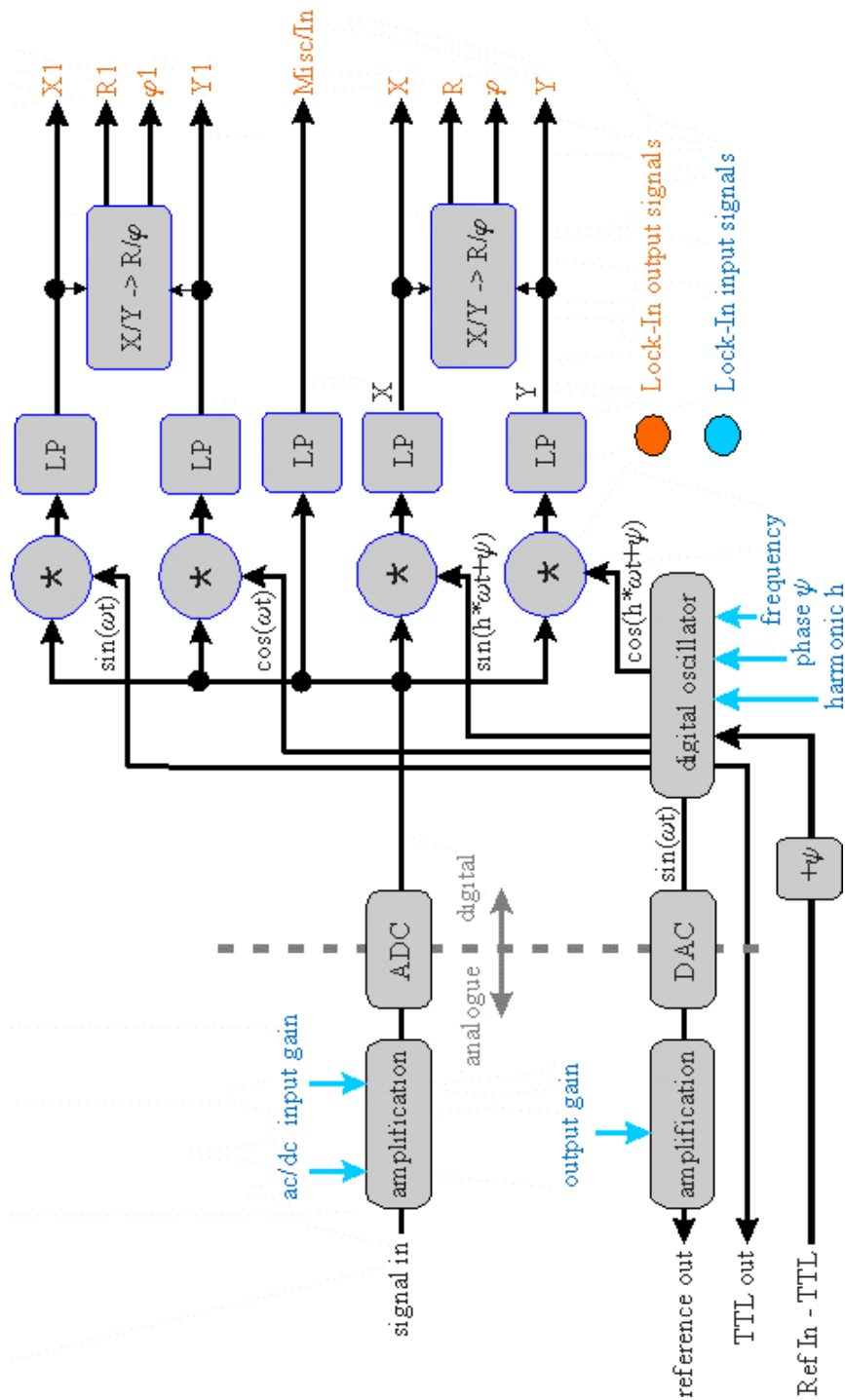

7.2 CALIBRATION CERTIFICATE

Anfatec Instruments AG
Melanchthonstraße 28
08606 Oelsnitz(V.)
Germany

Traceable Calibration
ELockIn
Cal Date:

CERTIFICATE OF TRACEABLE CALIBRATION

Certificate No:
Manufacturer : Anfatec Model: eLockIn Serial No:
Description: LockIn-Amplifier Temperatur: °C Humidity:..... %
Cal Date:

Anfatec recommends Cal Interval : 12 Months

Instrument Condition: new product

Anfatec certifies above instrument meets or exceeds published measurement specifications and has been calibrated using standards traceable to the PRC National Institute of Metrology (NIM) and/or other National Metrology Institutes (NIST, NPL,PTB) that are linked to the international system of units (SI).

Calibration Procedure: eLockIn.seq, Version 1.0a

Calibration Equipment used:

Manufacturer/Model	Model Description	Serial Number
Tektronix AFG3021	Generator	C010315
Tektronix TDS3032B	Scope	B028247
Fluke 8845A	AC-Multimeter	9281063

Certified By:

Date Issued:

7.3 TRACEABILITY CHART

